

10in.(25cm) BANDPASS ENCLOSURE  
**KSC-BP110**  
 SERVICE MANUAL

**KENWOOD**  
**OVERSEAS**

© 1996-6 PRINTED IN JAPAN  
 B51-7036-00(N) 1019

**EXTERNAL VIEW**

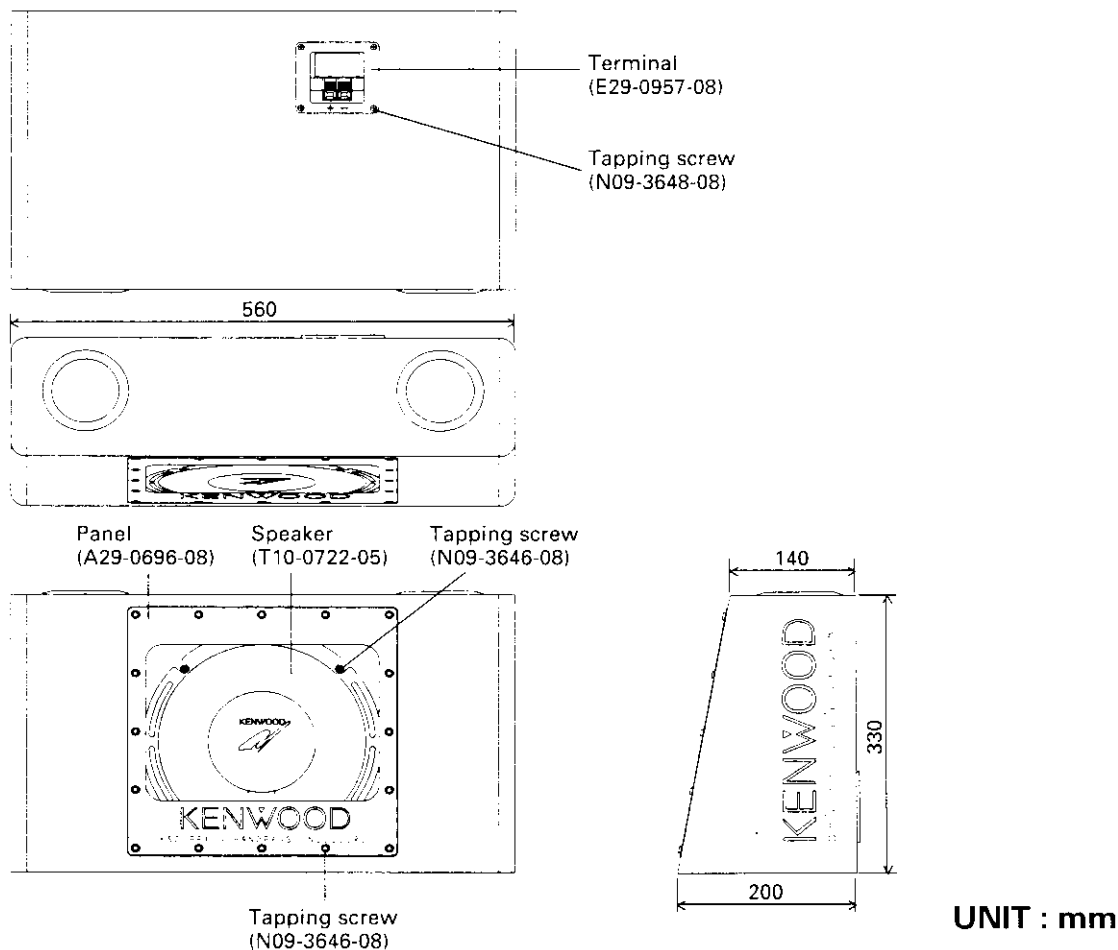

**UNIT : mm**

**PARTS LIST**

\* New Parts  
 Parts without **Parts No.** are not supplied.  
 Les articles non mentionnés dans le **Parts No.** ne sont pas fournis.  
 Teile ohne **Parts No.** werden nicht geliefert.

Ref No.	New Parts	Parts No.	Description
	*	A29-0696-08	PANEL
	*	E29-0957-08	TERMINAL
	*	E30-5348-08	SPEAKER CORD(M type only)
	*	E36-0112-08	CONNECTION CORD
	*	N09-3646-08	TAPPING SCREW
	*	N09-3648-08	TAPPING SCREW
	*	T10-0722-05	SPEAKER (WOOFER)

**SPECIFICATIONS**

**Note :**  
 KENWOOD follows a policy of continuous advancement in development. For this reason specifications may be changed without notice.

- System** ..... Bandpass speaker system
- Enclosure** ..... Bass-reflex type
- Mounted speaker**
- Woofer** ..... 250mm (10in) x 1: Rear mica cone type
- Impedance** ..... 4Ω
- Power handling**
- Peak input power** ..... 300W
- Maximum input power** ..... 200W
- Rated input power** ..... 100W
- Sensitivity** ..... 106dB/W in car (87dB/W at 1m)
- Frequency response** ..... 28Hz~170Hz
- Dimension**
- Width** ..... 560mm (22in)
- Height** ..... 330mm (13in)
- Depth** ..... 200mm (7-7/8in)
- Weight**
- Net weight (pc) without grill** .... 11.0g (24.3lb)
- Gross weight** ..... 12.5kg (27.6lb)
- Weight of magnet (Woofer)** ..... 567g (20oz)
- Special features** ..... Speaker cord (4.5m) (M.R.C type)